

extend
battery
life

improve
vehicle
availability

POWER CONTROLLER

1 TO 3 HOUR PROGRAMMABLE
BATTERY SAVER

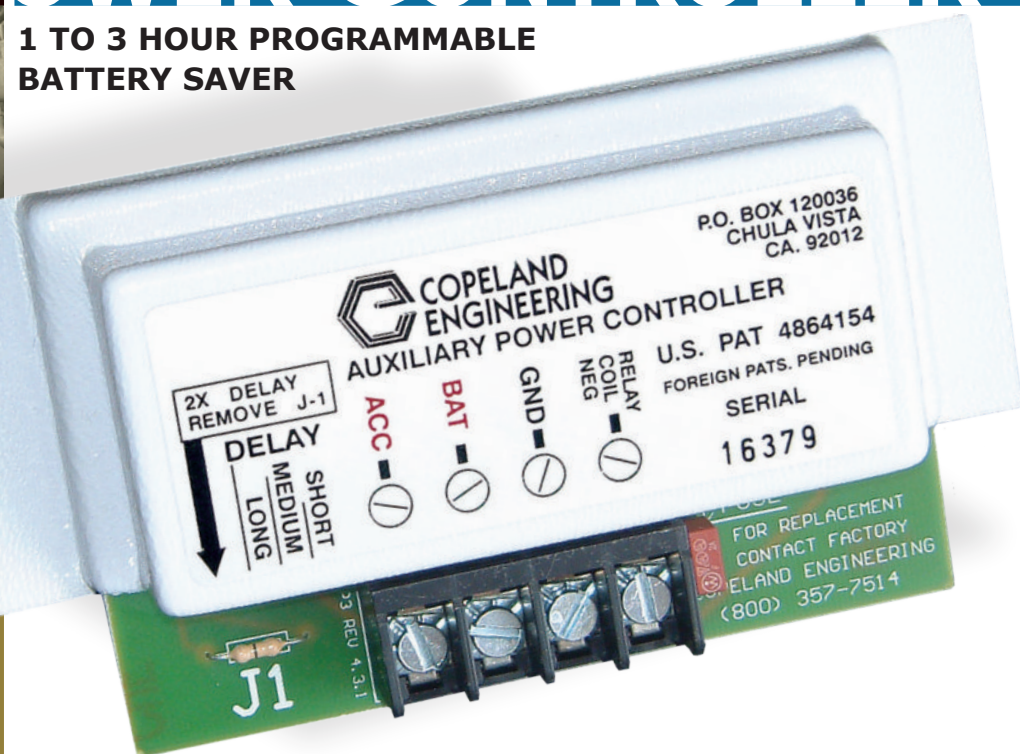
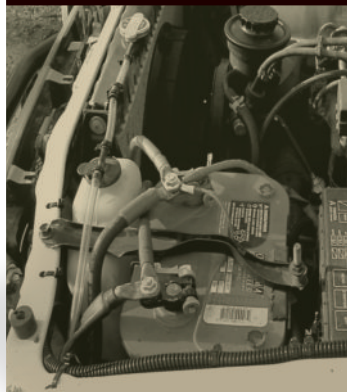

eliminate
monday
morning
battery
service calls



- **DIGITAL DESIGN**
Provide reliability and dependability over a wide temperature and voltage ranges
- **1 MILLIAMP STANDBY CURRENT**
Low standby current is important when vehicle is parked for extended times.
- **COMPACT**
- **RUGGED, HIGH IMPACT PLASTIC**
- **DIRECT IGNITION SENSING**
This circuit guarantees activation even if the engine will not start
- **PROGRAMMABLE FROM 1 TO 3 HOURS**
- **REQUIRES EXTERNAL SOLENOID OR RELAY**
- **LOW COST**

**ONE YEAR
WARRANTY**



Copeland Engineering, LLC
PO Box 120036
Chula Vista, CA 91912-3136
Tel: 619.575.4600 • Fax: 619.575.4646
www.copelandengineering.com

Call Us Toll Free
800.357.7514

Dedicated to Providing the Highest Quality Motor
Vehicle Electrical Products and Customer Support

POWER CONTROLLER INSTALLATION INSTRUCTIONS

1. Select the desired time delay from chart below.

Note that J-1 is a resistor body: cut to remove. Switch S-1 is a 3-position slide switch, accessed through the notch behind J-1.

2. Set Controller to delay time by moving the 3-position slide switch located behind J-1 (See Figure 1). This can be done with a ball point pen or small screwdriver. If the longer time on the chart is desired, remove J-1 with wire cutters.

3. Mount Controller under dash using the tabs on the case. (Tabs are not pre-drilled promoting flexibility in mounting.)

4. Mount the solenoid using your standard shop procedures.

5. Connect Controller as follows:

A. Wire solenoid to Controller as shown in Figure 1, using #14 or larger wire on the ground side of the solenoid coil. The positive side of the solenoid coil goes to the battery and to the BAT terminal on the Controller. The Controller itself draws negligible current so a # 18 wire is adequate for the BAT connection.

B. Connect the GND terminal to a chassis ground. This wire may carry up to 2 amps so keep it short and use # 14 wire if possible.

C. Locate an electrical connection which is only hot when the ignition switch is hot or in the accessory position. This is the point the Controller uses as its signal to begin timing. Wire this connection to the Controller terminal labeled ACC.

D. If you have disconnected the battery during installation, reconnect it now. **NOTHING WILL HAPPEN** until you turn the ignition switch on, taking your Controller out of "installation" mode.

- ▶ **NOTE:** If you disconnect the battery for any reason, the Controller reverts to "installation" mode. When the battery is reconnected, nothing will happen until the ignition switch is turned on, moving the Controller into "operational" mode.

CHART 1 MODEL 3A TIME IN HOURS AND MINUTES					
IF J-1 IS LEFT IN PLACE			IF J-1 IS REMOVED		
LONG	MEDIUM	SHORT	LONG	MEDIUM	SHORT
1:30	1:15	1:00	3:00	2:30	2:00

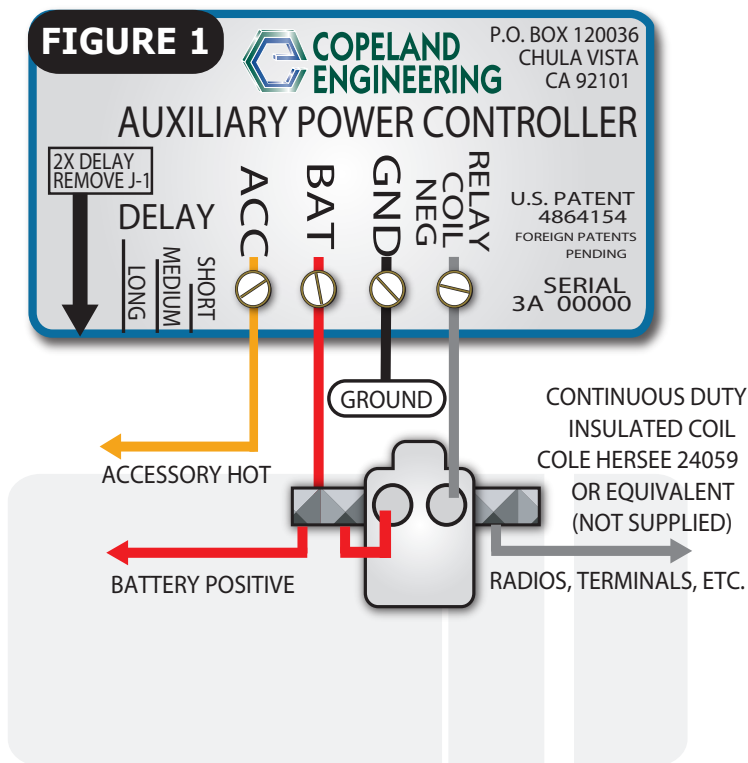

Copeland Engineering, LLC
PO Box 120036
Chula Vista, CA 91912-3136
Tel: 619.575.4600 • Fax: 619.575.4646
www.copelandengineering.com



Call Us Toll Free
800.357.7514